

Service Sheet No. AUC 9622 B
Jan. 1966

THE



CARBURETTER

Type HD

**TUNING, ADJUSTING, AND SERVICING
INSTRUCTIONS**

MANUFACTURED

by

THE S.U. CARBURETTER COMPANY LIMITED

WOOD LANE · ERDINGTON · BIRMINGHAM 24

TELEPHONE: ERDINGTON 7371 (9 lines)

TELEGRAMS: CARBURFLEX, BIRMINGHAM



© THE BRITISH MOTOR CORPORATION LIMITED 1966

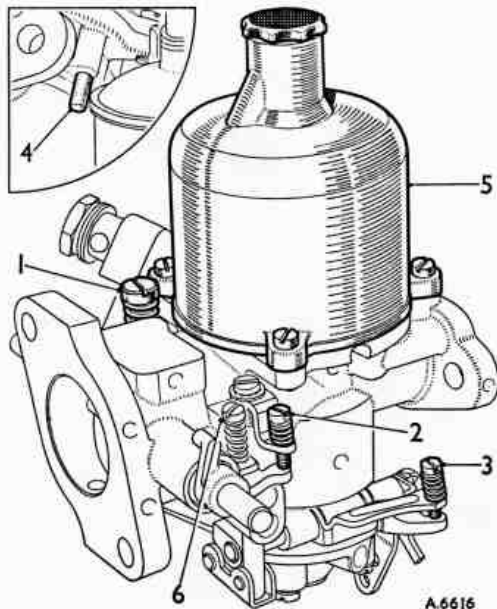

The Type HD Carburettor

- | | |
|-------------------------------|--|
| 1. Slow-running valve. | 4. Piston lifting pin. |
| 2. Fast-idle adjusting screw. | 5. Piston/suction chamber. |
| 3. Jet adjusting screw. | 6. Throttle adjusting screw (when fitted). |

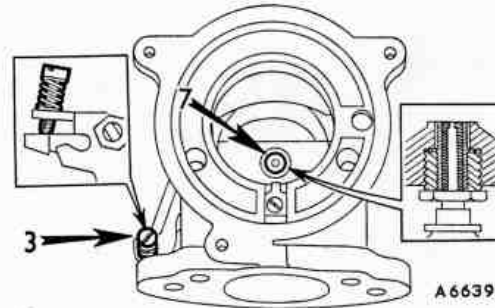

- 2
- A. Remove the piston/suction chamber unit.
- B. Turn the jet adjusting screw (3) until the jet (7) is flush with the bridge of the carburettor.

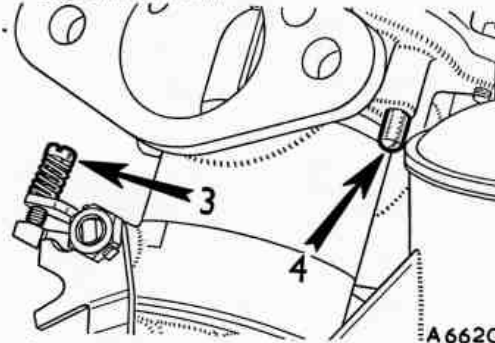

- 3
- A. Replace the piston/suction chamber unit.
- B. Check that the piston falls freely onto the bridge when the lifting pin (4) is released. If not, see items 15, 16, and 17.
- C. Lower the jet by turning the jet adjusting screw (3) down 2½ turns.

Tuning

Single carburettors

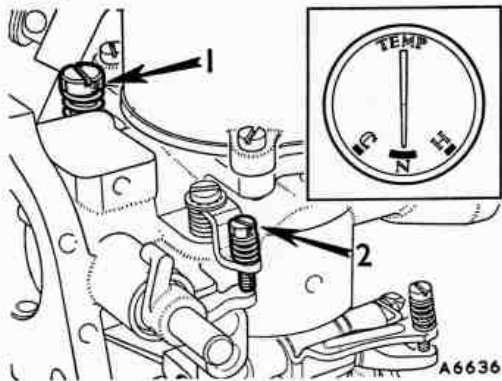

- 1
- A. Run the engine up to normal running temperature.
- B. Switch off the engine.
- C. Unscrew the fast-idle adjusting screw (2) to clear the throttle stop with the throttle closed.
- D. Screw down the slow-running valve (1) onto its seating, then unscrew it 3½ turns.

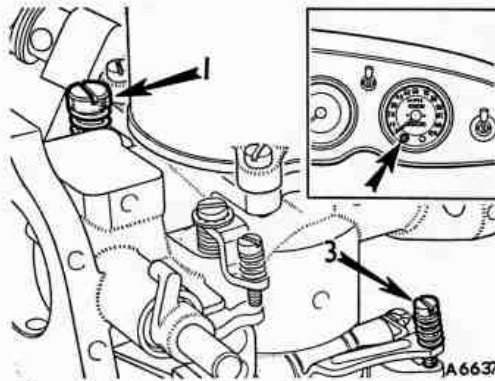

- 4
- A. Restart the engine and adjust the slow-running valve (1) to give the desired idling as indicated by the glow of the ignition warning light.
- B. Turn the jet adjusting screw (3), up to weaken or down to enrich, until the fastest idling speed consistent with even running is obtained.
- C. Re-adjust the slow-running valve (1), if necessary, to give correct idling.

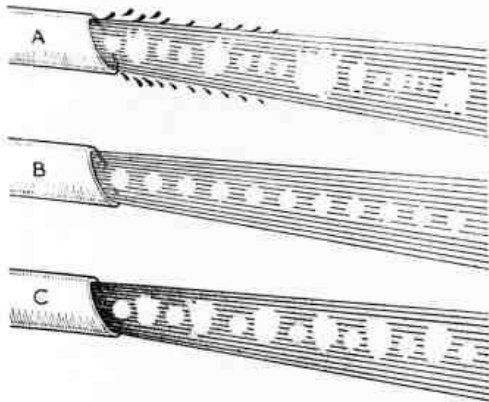

5

The effect of mixture strength on exhaust smoke.

- A. TOO WEAK: Irregular note, splashy misfire, and colourless.
- B. CORRECT: Regular and even note.
- C. TOO RICH: Regular or rhythmical misfire, blackish.

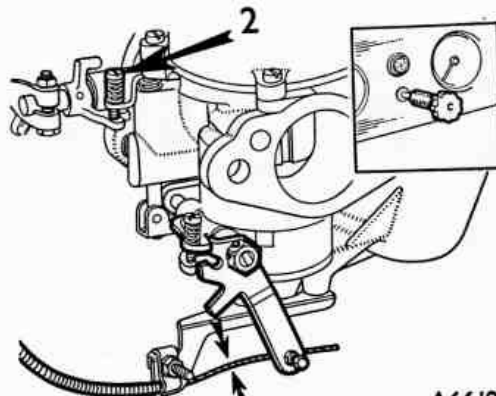

7

A6619

- A. Reconnect the mixture control wire with about $\frac{1}{16}$ in. (2 mm.) free movement before it starts to pull on the jet lever.
- B. Pull the mixture control knob until the linkage is about to move the carburettor jet operating arm and adjust the fast-idle screw (2) to give an engine speed of about 1,000 r.p.m. when hot.
- C. Return the control knob and check that there is some clearance between the fast-idle screw (2) and the throttle stop.

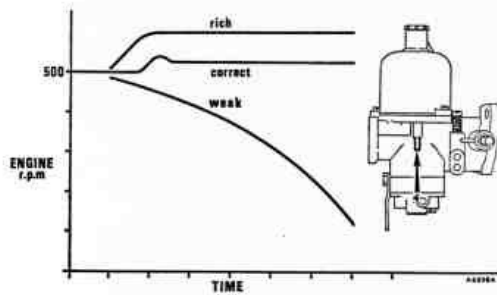

6

- A. Check for correct mixture by gently pushing the lifting pin (4) up about $\frac{1}{2}$ in. (1 mm.) after free movement has been taken up.
- B. The graph illustrates the effect on engine r.p.m. and indicated mixture strength when the piston is raised.
 - RICH MIXTURE: r.p.m. increase considerably.
 - CORRECT MIXTURE: r.p.m. increase very slightly.
 - WEAK MIXTURE: r.p.m. immediately decrease.
- C. Re-adjust the mixture strength if necessary.

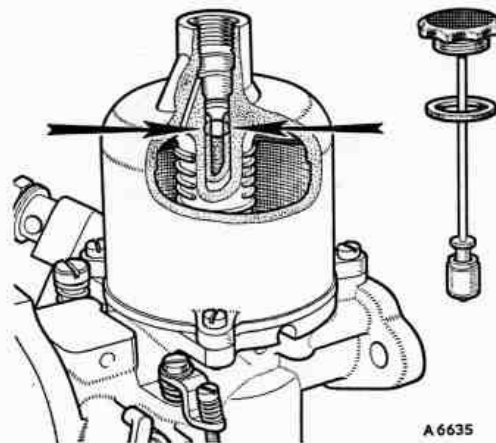

8

A6635

Finally top up the piston damper with the recommended engine oil until the level is $\frac{1}{4}$ in. (13 mm.) below the top of the hollow piston rod.

Note

On non-dustproofed carburettors, identified by a vent hole in the piston damper top, the oil level should be $\frac{1}{2}$ in. (13 mm.) above the top of the hollow piston rod.

Multi-carburettors

Multi-carburetter installations cannot be successfully tuned unless the tappets, points, and plugs are correctly adjusted. Remove the cleaners and carry out item 1, 2, and 3 on each carburetter.

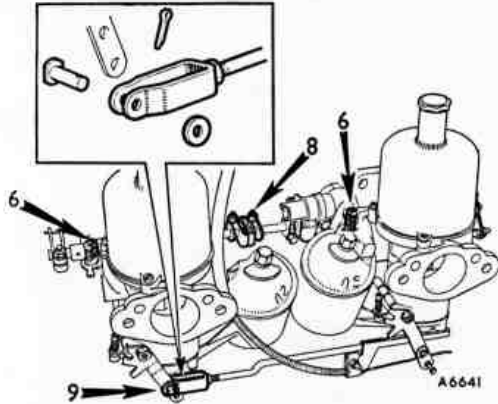

9

Note

Whenever the throttle adjusting screws (6) are fitted they, and not the slow-running valves, must be used to adjust the idling speed. Screw down the slow-running valves (which must remain closed) and set the throttle adjusting screws (6) $1\frac{1}{2}$ turns open. In items 10, and 11, adjust the idling speed with the throttle adjusting screws.

- Slacken a clamping bolt (8) on one of the throttle spindle inter-connection couplings between the carburettors.
- Disconnect the jet control interconnecting rod at the forked end (9).

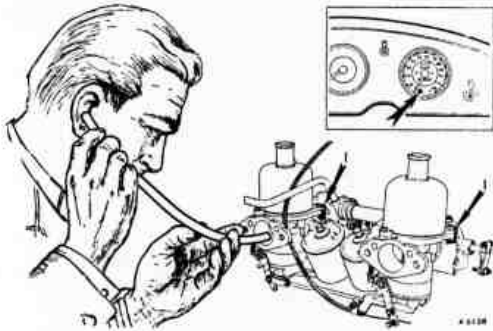

10

- Restart the engine and turn the slow-running valve (1), or throttle adjusting screws, an equal amount on each carburetter to give the desired idling speed as indicated by the glow of the ignition warning light.
- Compare the intensity of the intake hiss on all carburetters and alter the slow-running valves (1), or throttle adjusting screws, until the hiss is the same.

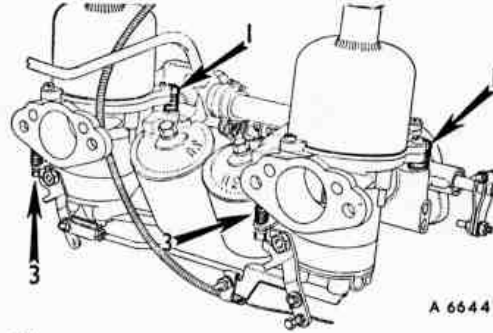

A 6644

11

- Turn the jet adjusting screw (3) an equal amount on all carburetters, up to weaken or down to enrich, until the fastest idling speed consistent with even running is obtained.
- Re-adjust the slow-running valves (1), if necessary.

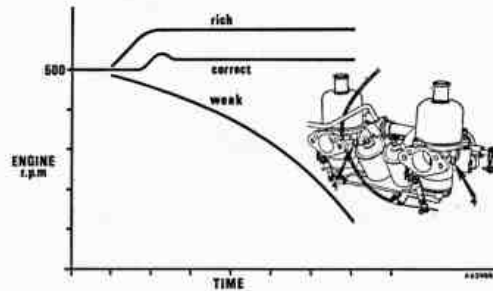

12

- Check the mixture by raising the lifting pin (4) of the front carburetter $\frac{1}{8}$ in. (1 mm.) after free movement has been taken up. The graph illustrates the possible effect on engine r.p.m.
- Repeat the operation on the other carburetter(s) and after adjustment re-check as the carburetters are interdependent.
- Item 5 shows the effect of mixture on the exhaust smoke.

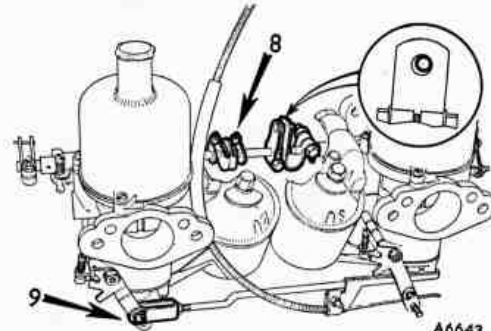

A6643

13

- Tighten the clamp bolt (8) of the throttle spindle interconnections with the pin of the link pin lever resting against the edge of the pick-up lever hole (see inset). This provides the correct delay in opening the front carburetter throttle. When a forked lever is fitted, set the lever so that the pin is .006 in. (15 mm.) from the lower edge of the fork.
- Reconnect the jet control linkage (9) so that the jet operating arms move simultaneously; if necessary, turn the fork end(s).

Tuning multi-carburetters (continued)

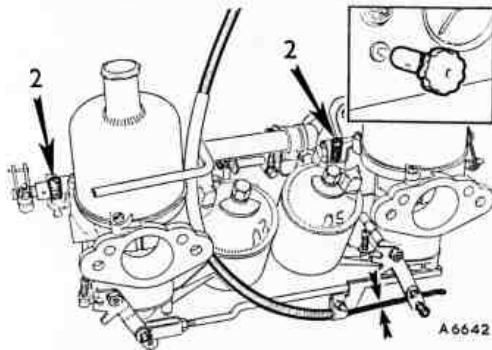

14

- Reconnect the mixture control wire with about $\frac{1}{8}$ in. (2 mm.) free movement before it starts to pull on the jet levers.
- Pull the mixture control knob until the linkage is about to move the carburettor jet operating arms, and adjust the fast idle screws (2) to give an engine speed of about 1,000 r.p.m. when hot.
- Return the control knob and check that there is a small clearance between the fast idle screws and the throttle stops.
- Refit the air cleaners.

Note

When an auxiliary (thermo) carburettor is fitted refer to Service Sheet No. AUC 9796.

Adjusting and Servicing

Jet centring

15

The piston should fall freely onto the carburettor bridge with a click when the lifting pin is released with the jet in the 'fully up' position. If it will only do this with the jet lowered then the jet unit requires re-centring. This is done as follows:

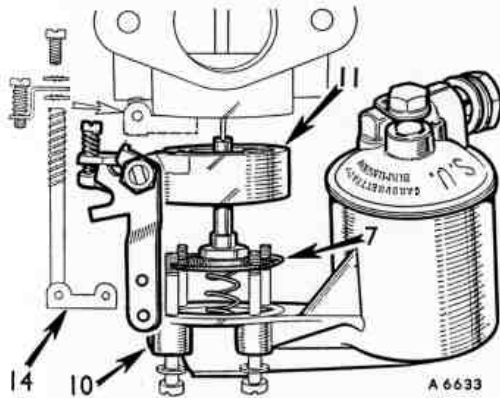

16

- Mark the position of the jet housing and float-chamber in relation to the carburettor body for reassembly.
- Remove the plate retaining screw and withdraw the cam rod assembly (14).
- Unscrew and remove the float-chamber securing screws.
- Remove the float-chamber (10) and the jet housing (11) and release the jet assembly (7).

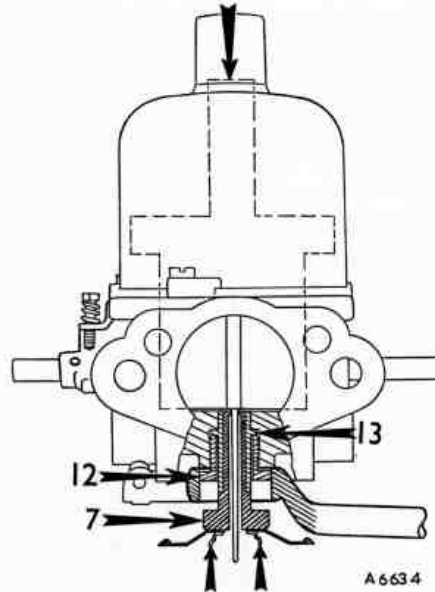

17

- Slacken the jet locking nut (12), using a ring spanner, until the jet bearing (13) is just free to move.
- Remove the piston damper, hold the jet (7) in the 'fully up' position, and apply light pressure to the top of the piston rod. Tighten the jet locking nut (12).
- Check again as in item 15 and ensure that the jet moves down the bearing freely.
- Reassemble, ensuring that the jet and diaphragm are kept to the same angular position and that the beaded edge of the diaphragm is located in the housing groove.
- Refill the piston damper with oil (see item 8.).

Cleaning

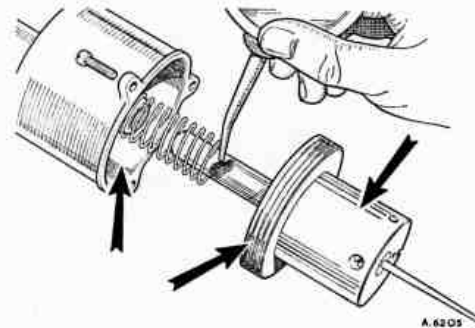

18

- Remove the piston/suction chamber unit.
- Using a petrol-moistened cloth, clean the inside bore of the suction chamber and the two diameters of the piston.
- Lightly oil the piston rod only and reassemble.

Adjusting and Servicing (continued)

Float-chamber fuel level

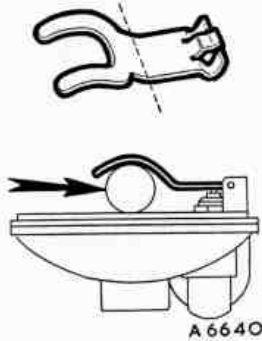

19

- A. Remove and invert the float-chamber lid.
- B. With the needle on its seating, insert a $\frac{1}{16}$ in. (11 mm.) diameter bar between the forked lever and the lip of the float-chamber lid.
- C. The prongs of the lever should just rest on the bar. If they do not, carefully bend at the start of the pronged section until they do.

Needle size and position

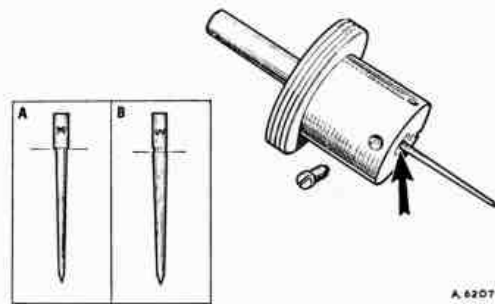

20

The needle size is determined during engine development and will provide the correct mixture strength except under extremes of temperature, humidity, or altitude; e.g. a weaker needle will be necessary at altitudes exceeding 6,000 ft. (1800 m.). If modifications are made to the engine; (e.g. camshaft, compression ratio, air cleaner, or exhaust system) a different needle may be necessary to maintain performance.

- A. To check the needle fitted, remove the piston/suction chamber unit.
- B. Slacken the needle clamping screw, extract the needle, and check its identifying mark against the recommendation.
- C. Fit the correct needle and lock it in position so that the shoulder on the shank (A), or the lower edge of the groove (B), is flush with the piston base.
- D. Reassemble the piston/suction chamber unit.

Faults

Symptom	Cause	Remedy	Item No.
Erratic running Stalling at idling Lack of power High fuel consumption	Sticking piston: Dirty piston and suction chamber Jet out of centre Bent needle	Clean Re-centre Fit new	18 15, 16, and 17 20
Hesitation at pick-up	Low damper oil level Incorrect oil grade (too thin)	Top up Replace with correct grade	8 8
Float-chamber flooding	Dirty or worn float-chamber needle valve (dirty fuel) Punctured float Incorrect fuel level	Clean or renew valve (flush system) Fit new Check and reset level	See Dismantling and Reassembly Leaflet 19